

Using Spatial Hypertext to Visualize Composite Knowledge in Emergency Responses

José H. Canós

Dept. of Computer Science (DSIC)
Universidad Politécnica de Valencia
Valencia, Spain
jhcanos@dsic.upv.es

M^a Carmen Penadés

Dept. of Computer Science (DSIC)
Universidad Politécnica de Valencia
Valencia, Spain
mpenades@dsic.upv.es

Carlos Solís

Lero, The Irish Software Engineering Research
Centre
University of Limerick
Limerick, Ireland
Carlos.Solis@lero.ie

Marcos R. S. Borges

Graduate Program in Informatics
Instituto de Matemática & NCE
Federal University of Rio de Janeiro
Rio de Janeiro, Brazil
mborges@nce.ufrj.br

Manuel Llavador

Dept. of Computer Science (DSIC)
Universidad Politécnica de Valencia
Valencia, Spain
mllavador@dsic.upv.es

ABSTRACT

Having the right information at the right time is crucial to make decisions during emergency responses. To fulfill this requirement, emergency management systems must provide emergency managers with knowledge management and visualization tools. The goal is twofold: on one hand, to organize knowledge coming from different sources, mainly the emergency response plans (the formal knowledge) and the information extracted from the emergency development (the contextual knowledge); on the other hand, to enable effective access to information. Formal and contextual knowledge sets are mostly disjoint; however, there are cases in which a formal knowledge piece may be updated with some contextual information, constituting what we call the composite knowledge. In this paper, we extend a knowledge framework with the notion of composite knowledge, and use spatial hypertext to visualize this type of knowledge. We illustrate our proposal with a case study on accessing to information during an emergency response in an underground transportation system.

Keywords

Knowledge Management, Emergency Response, Emergency Response Plan, Composite Knowledge, spatial hypertext

INTRODUCTION

Emergency responses are among the most critical activities performed by humans: processes where decisions affecting lives and properties must be made in short time. These decisions must be made from information coming from different sources, which must be accessed and combined adequately to avoid both information lacks and overloads. Moreover, different decision makers may require different information elements or, at least, different views of them. For instance, decision makers at a control room may have more sophisticated means to access to the information than the responders working at the emergency location, carrying mobile devices with reduced graphical capacity. Thus, information management is becoming a key aspect of modern emergency management systems.

Reviewing Statement: This paper has been fully double blind peer reviewed.

The emergency response plan is a document that includes the procedures to be activated in response to any type of incident, plus all the information required to make decisions (such as maps, pictures, videos, etc.). The advance of information technologies has enabled the development of rich-content emergency response plans, going beyond the classical printed documents to become sophisticated hypermedia structures integrating text and multimedia content to provide decision makers and responders with the most accurate information. Typical cases of rich information are the use of Geographical Information Systems to calculate the optimal road to an emergency location, or video recordings of the different sections of a subway tunnel. Nevertheless, a valuable part of the information required to solve emergencies cannot be available in advance, as it must be gathered from the emergency location; this information is known as the context of the emergency, and may be very relevant for decision making. For instance, routes calculated by route planners may be unusable in case of avalanches or earthquakes or even traffic jams, so they should not be used by response teams.

In general, contextual information is complementary to the context-independent one; that is, there are parts of emergency response plans considered contextual, and the plans include the necessary actions to gather such information and make it available to decision makers. In some cases, context overrides non-contextual information previously available. For instance, if a road is closed, some request should be sent to the route planner to recalculate and find a clear way to the place. In other cases, overriding is not recommendable, as previously recorded information can still be valuable. If a tunnel has collapsed, the video of the tunnel should not be shown as an optional escape way, but could be still available to look for valuable information such as possible obstacles, or just to analyze properties of tunnels similar to the damaged one for which there is no video recording available.

Managing contextual information poses several challenges, from its capture to its visualization. Specially challenging is how to have access to both contextual and non-contextual information related to the same object (e.g. the road and the tunnel in the aforementioned cases). Having the appropriate mechanisms is important as wrong information can lead to wrong decisions. In this paper, we tackle the problem of combining contextual and non-contextual information to make it available to decision makers in emergency responses. With this aim, we define a framework for knowledge representation and visualization. The framework builds on previous work on knowledge management and hypermedia engineering to provide a solution for knowledge organization and visualization.

Starting from a context-enabled knowledge model, that includes the so-called composite knowledge, we create emergency response plans whose components can be labeled with the different types of knowledge (contextual, non-contextual or formal, and composite). Then, we define transformation rules to generate hypermedia navigational structures that, being technology-independent, provide structure and navigation to the information space an emergency response plan is. Finally, specific plan realizations can be made using different hypermedia languages. We have selected ShyWiki (Solis and Ali, 2008), a spatial-hypertext Wiki system which enables the superposition of different types of knowledge in terms of spatial properties such as position, color, etc. This way, all types of information can be defined and used collaboratively following the Wiki paradigm.

We illustrate the use of our approach with the case of a subway transportation system; our experience in the development of a hypermedia emergency response plan revealed the need to cope with composite knowledge. We show how ShyWiki allows the superposition of different types of information to enrich the expressiveness of previous plans.

The paper is structured as follows. In the next section, we define a knowledge management model which extends the one presented in (Diniz, Borges, Gomes and Canós, 2008) with the notion of composite knowledge. Then we show how composite knowledge can be included in emergency response plans via the use of stereotypes in the definition of an emergency response plan model. Later, we show how to turn emergency response plans into navigational structures, to conclude with the generation of spatial hypertext plans using ShyWiki. A discussion of our approach and a mention to further work concludes the paper.

KNOWLEDGE MANAGEMENT IN EMERGENCY RESPONSE

The emergency response phase starts when a dangerous situation needing immediate action occurs. Response teams, composed of well-trained members who may belong to more than one organization - for instance, firefighters and policemen - perform diverse activities oriented to mitigate the effect of the emergency on people and property. The diversity of actors makes decisions mostly collaborative, as the different organizations involved must communicate with each other, creating a large body of shared knowledge and using it to make most decisions during the response process. From the knowledge managed during the emergency response, decisions are made that result in actions to mitigate the effect of incidents.

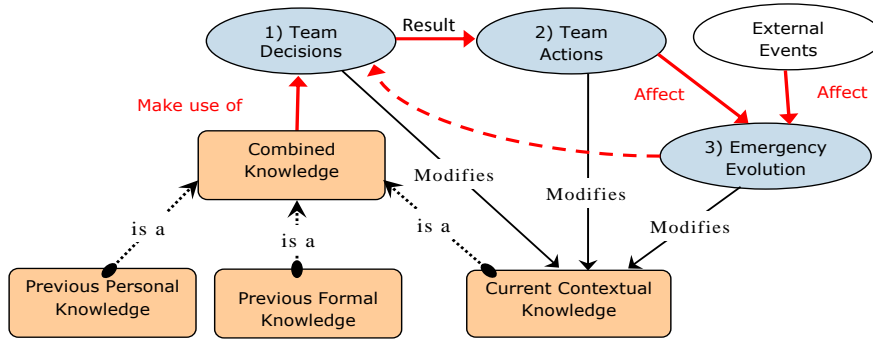
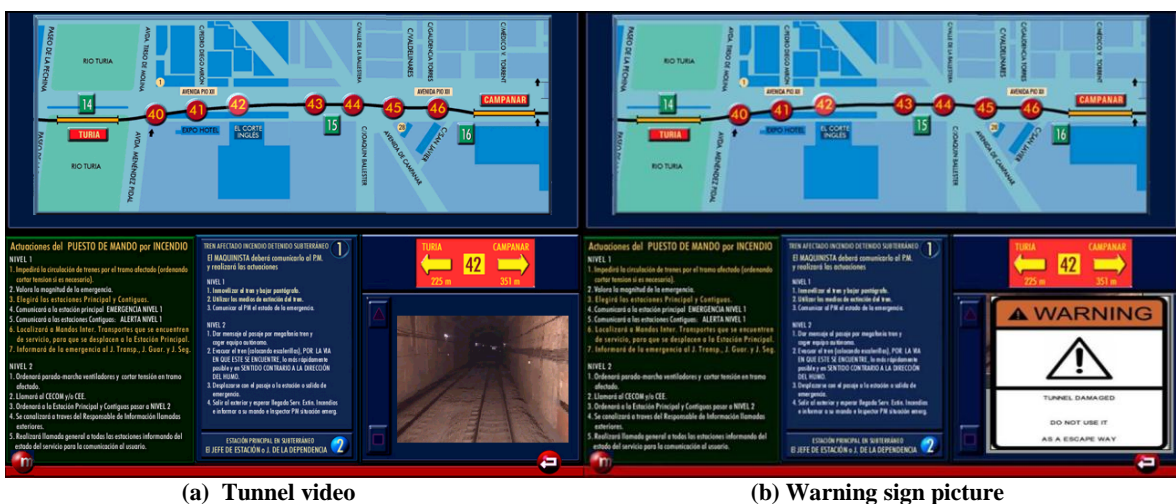

Figure 1. Conceptual map of knowledge support during an emergency response phase (Diniz et al., 2008)

Managing and accessing to such knowledge is not an easy task due to several reasons. First, the sources of knowledge are in general heterogeneous and distributed, which require the implementation of some interoperability mechanisms as part of the emergency management systems. Second, the sources may be static or dynamic, depending on whether the information they provide is stable or may change during the development of the response. Third, the sources may be explicit or implicit; by explicit we mean that the information source is identified (e.g. the emergency response plan) and access mechanisms provided; conversely, an implicit source is such that it is not known in advance, and hence must be dealt with immediately after the source is discovered.

The knowledge can be available in different forms, and be of different nature, as pointed out by (Diniz et al., 2008) and illustrated in Figure 1, which summarizes the decision making process in emergency response. The experience and background of emergency responders constitute the so-called Previous Personal Knowledge (PPK). In general, a good PPK reduces the time needed to make decisions as autonomy of responders is enforced. However, it is difficult to handle as it is tacit, highly personal and hard to formalize (Nonaka and Takeuchi, 1995). As a complement to PPK, explicit knowledge is originated in some information sources, and may belong to two categories: on one hand, the Previous Formal Knowledge (PFK) is generated in advance, as a result of the prevention activities, and does not change during the development of the emergency; in general, PFK is contained in the emergency response plan. On the other hand, Current Contextual Knowledge (CCK) is composed of all the information which cannot be compiled in advance because it is mostly generated during the development of the emergency, and may even change during the emergency evolution. Sometimes the CCK pieces are known to be needed (e.g. the location of train running through a tunnel), and hence some type of placeholder could be inserted in an emergency response plan (e.g. "...request the location of the train..."); other times, however, CCK elements are not known in advance as they are generated during the emergency (e.g. a responder may communicate to the command and control the presence of a toxic leak near a hospital, which requires immediate evacuation of the building).

In general, information sources can be classified in one of the categories included in the framework. However,



(a) Tunnel video

(b) Warning sign picture

Figure 2. Screenshots of hypermedia emergency response plan on a subway service (adapted from Canós et al., 2004)

there are cases in which the nature of the information source introduces some overlaps. Figure 2a shows a screenshot of a hypermedia emergency response plan on a subway service (Canós, Alonso and Jaén, 2004). There, information of different types is used to represent part of the actions to be performed by responders when a train catches fire inside a tunnel: instructions for the train driver expressed in natural language, a surface street map, and a video of the tunnel to help emergency coordinator to find obstacles for the evacuation of passengers. The video is shown in a region that includes playing controls. All the information pieces shown can be classified as PFK, since they are explicit and known in advance. However, there may be situations where PFK should not be used: if the fire in the train has been originated by a larger event such as an earthquake, the tunnel may have collapsed, and hence the video showing a clean tunnel should not be used at all because passengers can be driven to a dangerous place. In this case, some alternative information should replace the video (e.g., a warning sign picture preventing the evacuation through the tunnel) and then, the screenshot of the emergency response plan changes, as Figure 2b shows.

The above example illustrates what we call in this paper *composite knowledge*: information that is formalized, but may be replaced (or, at least, updated) with contextual information. Unlike Situated Knowledge (Gahegan and Pike, 2006), which refers to the influence of context during the PFK creation processes, we extend the PFK with information generated at the knowledge use time. In general, replacing a formal source by a contextual one does not mean overriding. Even in the case of an unusable tunnel, the emergency coordinator may still be interested in having access to the tunnel to study some characteristics which may be helpful to make a decision. In this case, the ability to access to both the formal and contextual information must be provided by the information visualization tools of Emergency Management Systems. In this paper we will focus on the representation and access to composite knowledge during emergencies.

INCLUDING COMPOSITE KNOWLEDGE IN EMERGENCY RESPONSE PLANS

An emergency response plan is a complex document that includes the coordination mechanisms among responders, the procedures to be executed by the different actors involved, and the information to be exchanged between them. As mentioned earlier, emergency management systems use these plans as the main source of knowledge to drive the emergency response and the information contained is mostly composed of instances of PFK, as they have been defined in advance. CCK sources can also be included in emergency response plans, whenever they are identified in advance. Obviously, PPK is out of the scope of the plans as we are focusing on explicit knowledge. Specifically, we are interested in including and supporting visualization of composite knowledge pieces. With this aim, we define a knowledge model that will be combined with domain models to create rich emergency response plan models.

Figure 3 shows the UML class diagram representing our Knowledge Model. Knowledge is stored in *InfoElements*, which can be formal (*FormalIE* class), contextual (*ContextualIE* class) or composite (*CompositeIE* class). A composite element has a formal component associated (its base element), and may have associated one or more contextual elements. In general, formal and contextual elements are represented as digital objects which can be visualized using one or more disseminators, e.g. image viewers, video players, etc. (Kahn and Wilensky, 1995).

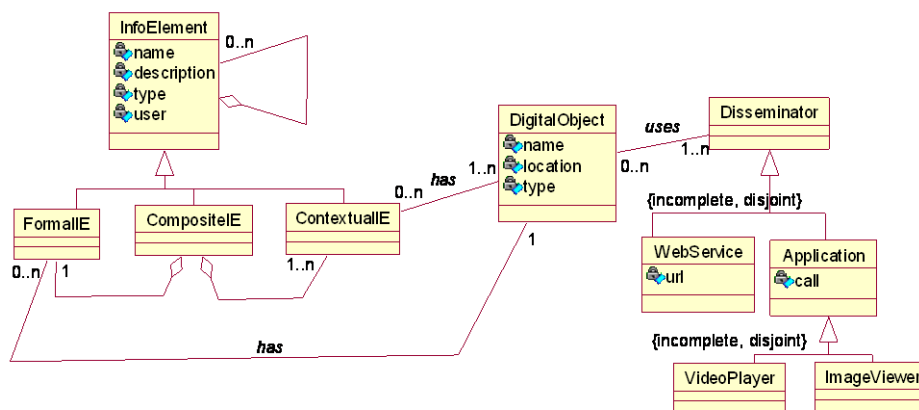

Figure 3. Knowledge Model including Composite Knowledge

InfoElements can be composed. The pages shown in Figure 2 can be described in terms of the Knowledge Model as an *InfoElement* composed of the following elements:

- a surface map combined with the tunnel map (top of the screen). It is a formal element, represented as an image (a digital object of type image) and visualized using some image viewer;
- three text boxes, one at the bottom left and other two composing the compound element shown in the bottom center of the Figure. All boxes are formal elements, too. The user may switch from one to the other one clicking on the numeric labels associated to each text (which is part of the behavior of its associated disseminator);
- a distance indicator (the red box in the center, right part of the screen), indicating the distance of the train to the closest stations. It is a contextual element since the distances are calculated during the development of the emergency, and is represented by an image generated on demand by a specialized disseminator; and
- a composite element representing the tunnel; on one hand, a piece of formal knowledge, a video, which corresponds to the usual tunnel's appearance and can be disseminated by means of the appropriate video player; on the other hand, a contextual element, the warning picture, which should be shown in case of a tunnel collapse. In Figure 2b, the picture is hiding the video; however, it may be useful to access to the video if some valuable information can be extracted from it.

There are other elements in the page which cannot be described in terms of the knowledge model, as they have been included to give structure to the plan, allowing the navigation throughout its structure; they are described in further models.

Developing Rich-Content Emergency Response Plans

The emergency response plan designers specify the mechanisms to respond to the different incidents that may affect the organization, as discussed above. However, the structure of the emergency response plan, as well as the specific information it contains may vary depending on issues like legal regulations or the type of organization considered. Whatever the particular issues are, the process to develop knowledge-aware emergency response plans can be summarized as follows: first, an emergency response plan model is built which defines the structure and content of them according to the particular settings. Second, this model is combined with the Knowledge Model defined in the previous section classifying the different emergency response plan components as formal, contextual or composite information pieces. To illustrate our approach, we have specified an emergency response plan model based on the legal regulation in Spain, called “Norma Básica de Autoprotección” (NBA, www.boe.es/boe/dia/2007/03/24/pdfs/A12841-12850.pdf), that specifies the structure and minimal content of an emergency response plan. According with this regulation, an emergency response plan belongs to an organization, has a responsible, identifies a set of risks and contains a collection of emergency procedures. A complete description about the business activities is required, including the organizational structure. The emergency response plan must also contain a systematic warning system enumeration and a complete set of maps about the organization location and infrastructure. The emergency procedures, called action plans, not only contain the activities to perform by the response teams, but also the resources used and their responsible, the alarm mechanism and evacuation plans.

Figure 4 shows a simplified view of the emergency response plan model as UML class diagram. The Knowledge Model has been included in the form of *stereotypes*. Each element of the emergency response plan model is considered a piece of knowledge -an *InfoElement*- and can be labeled as formal, contextual or composite knowledge (`<<formal>>`, `<<contextual>>` and `<<composite>>` *stereotypes*, respectively). Notice that in the example, the knowledge about the organization, their business activities and their employees is considered formal. Many other classes are labeled as composite, assuming the possibility of having associated contextual information. This may vary from one emergency response plan model to another one, and therefore, assigning a stereotype to each emergency response plan component is a modeling decision.

Table 1 lists the different components appearing at the screenshot of the hypermedia emergency response plan on a subway service shown in Figure 2. For example, the *ActionPlan* instance is shown as three different views of formal knowledge, one per each different actor involved in the response. Fragment a) represents the procedure to be executed by the emergency coordinator, and fragments b) and c) represent the activities which are responsibility for the train driver and the station chief, respectively. In the case of the *Map* instance called *TunnelView*, the emergency response plan designer decided to assign the *composite stereotype* and hence both the digital objects that represent the formal knowledge- in this case, a recorded video of the tunnel- and the contextual knowledge, a warning sign picture that must be shown if a tunnel is not a safe way- must be specified.

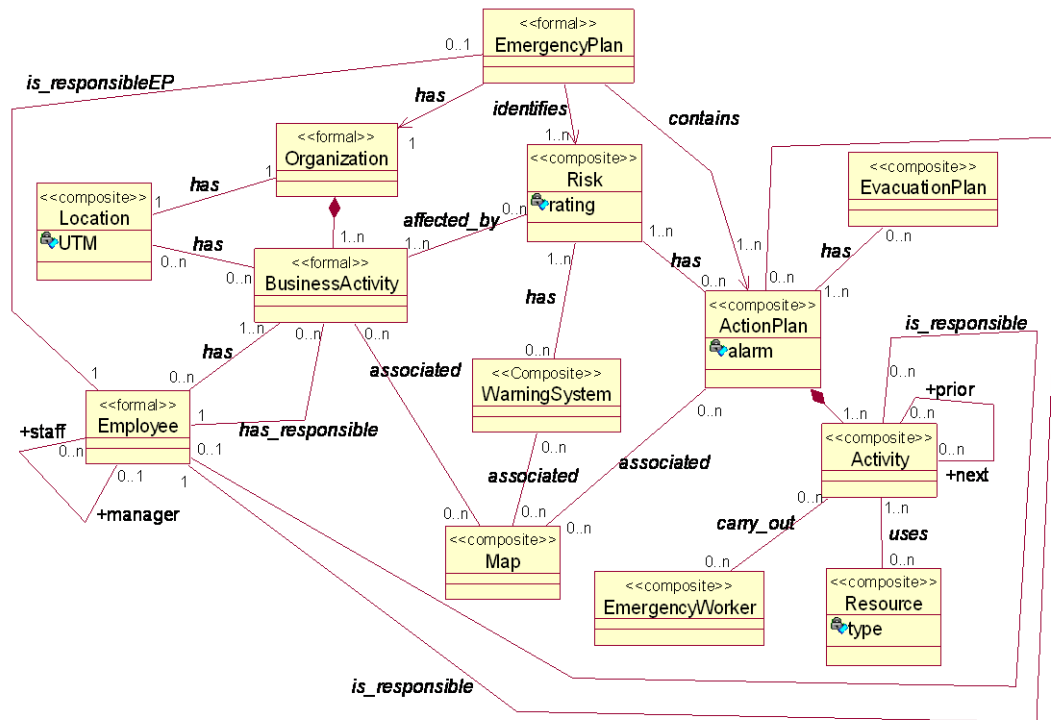

Figure 4. Emergency Response Plan Model based on the NBA.

Class	ActionPlan	Map		EvacuationPlan
Instance	Fire Inside a Tunnel	Surface Street Map	Tunnel	Distance Indicator
Stereotype	<<formal>>	<<formal>>	<<composite>>	<<contextual>>
Digital Object				

Table 1. Emergency Response Plan Components in “Fire Inside a Tunnel” in a subway service

TURNING EMERGENCY RESPONSE PLANS INTO NAVIGATIONAL STRUCTURES

The emergency response plan model described is technology-independent. To build actual plans, some path must be followed from modeling languages to implementation languages. Assuming that our goal is to generate rich-content, hypermedia emergency response plans, we need to turn the class-based description into a navigational structure. Due to the variety of hypermedia formats available, we decided to create an abstract representation of such structure, which can be easily transformed into actual hypermedia models, as we will show in the following section. Figure 5 shows a partial view of the so-called Knowledge Graph Model; we represent the emergency response plan as a graph composed of nodes. The notion of node corresponds to that of page in hypermedia documents, that is, a collection of information pieces that are grouped and shown in a

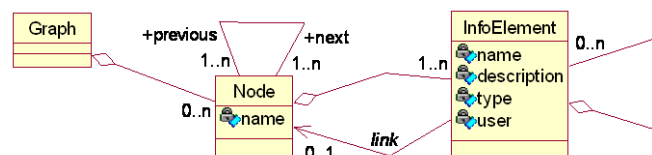

Figure 5. Knowledge Graph Model (partial)

coherent way. These pieces (the *InfoElements*) are the components of the emergency response plans, some of which can include hyperlinks to other nodes in the graph.

The classical Hypermedia Engineering techniques (Schwabe and Rossi, 1995; Ceri, Fraternali and Bongio., 2000; Solís, Canós, Penadés and Llavador, 2006) can support the graph generation process. Specifically, navigational design techniques include heuristics to generate a navigable structure from class diagrams, transforming classes into navigable elements and class relationships such as associations into links between them. Additionally, some abstract interface techniques can help grouping the different elements into nodes to generate consistent and effective user interfaces. In the example about “Fire Inside a Tunnel” in a subway service, we have considered all *InfoElements* compound the same graph node.

VISUALIZING EMERGENCY RESPONSE PLANS USING SPATIAL HYPERTEXT

Abstract navigational emergency response plan graphs must be realized into some existing technology to make them accessible to emergency responders. As mentioned earlier, hypermedia (or hypertext) appears as the natural target model as their models are similar to the navigational model introduced in the previous section. Since its conception, hypertext has been thought as a way for helping people to access to knowledge, in a kind of augmentation of the human intellect (Bush, 1945; Engelbart, 1963). However, knowledge creation tasks were not supported by hypertext tools until very recently. Wikis (Leuf and Cunningham, 2001) have emerged as an effective hypertext technology for enabling organizations and individuals to both capture and share knowledge. The advantage of using Wikis for knowledge management is that the management tasks can be performed in an open, collaborative and distributed way. Wiki philosophy fits very well with the common collaborative way of defining and utilizing emergency response plans. However, wikis have not overcome all the problems of original hypertext. Specifically, the documented-centered nature of hyperdocuments made users get lost using hyperlinks as the only means to navigate in large networks. This is the case of emergency response plans, which may be large and complex documents.

Spatial hypertext (Marshall and Shipman 1995) is based on using visual and spatial characteristics of hypertext elements for defining the relationships among them. The elements of a spatial hypertext document are seen as cards that are classified through visual clues, or spatial positions. When these characteristics are used to relate elements, the hyperlinks become implicit, and related elements can be represented by sharing the same visual and spatial characteristics: a color, borders, font types, adorns layouts, position, proximity, geometric relations, etc. Using spatial hypertext features, superimposed information can be visualized easily, bringing the right way to visualize the composite knowledge. Merging these features with a wiki-like model for information capture and visualization, we will have the key to building rich-content emergency response plans.

ShyWiki (Solís and Ali, 2008) is a wiki which uses spatial hypertext for representing its content. It was designed to support users in creating, storing, editing, and browsing knowledge structures, understood as interconnected networks of information. ShyWiki manages a network of wiki pages (the nodes of the network). Each page is a hypermedia document that is identified by its name and is made up of an unordered set of named attributes called notes. Wiki page notes can contain text, images, and hyperlinks, or a mix of them. The main function of the notes is to define the attributes that characterize the concept represented by a wiki page.

The content of the wiki pages is spatially organized: notes may be placed in different regions of the page, moved around, and may be of different sizes and colors. The notes can contain text, hyperlinks, and images. Composite notes may be created from simpler ones, helping to organize knowledge hierarchically.

The components of the ShyWiki Hypertext Model are summarized in Figure 6. The root of a ShyWiki document is the ShyWikiWeb, which is composed of information and knowledge stored in WikiPages, connected by hyperlinks. The WikiPages are composed by notes. The AbstractNote class includes the properties which are common to the two types of notes: on one hand, ContentNotes hold content of different types (text, images, video and hyperlinks) and can be composed of other ContentNotes; and on the other hand, the so-called TranscludedNotes. Transclusion is the inclusion of notes already defined in other wiki pages by reference, i.e., without duplicating them in the including note. Essentially, a TranscludedNote is a note whose content is

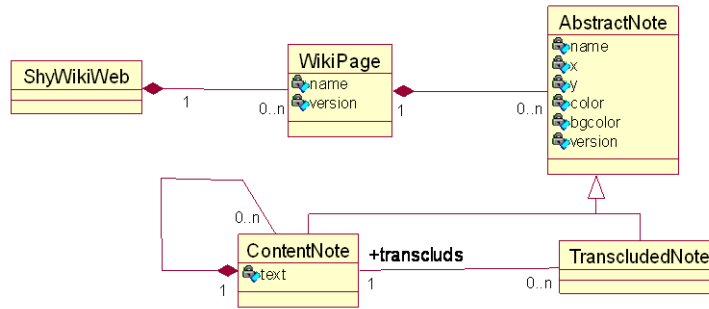

Figure 6. ShyWiki Hypertext Model

defined by another note. ShyWiki supports this model providing the basic operations to create or modify wiki pages. In the edition mode, a user can perform a number of knowledge management actions, namely creating wiki pages, and creating, editing, moving grouping and transcluding notes. These actions permit to represent easily the composite knowledge.

ShyWiki is a service oriented wiki. ShyWiki web client interacts with the server using Asynchronous JavaScript and XML (AJAX) web services. These services can be used by other agents different than a web browser to interact with ShyWiki. ShyWiki's web services allow external agents to write or read the content of the wiki pages. So, emergency management systems can connect to ShyWiki servers to generate personalized information for the different responders.

Generating ShyWikis from Knowledge Graph Models

Elements in the Knowledge Graph Model are transformed in ShyWiki spatial hypertext elements. Figure 7 shows the wiki page generated from the emergency response plan components shown in Table 1. The following paragraphs illustrate the process followed to obtain it.



Figure 7. “Fire Inside a Tunnel” ShyWiki page

A knowledge graph is represented as whole Wiki. Nodes in the graph are transformed into wiki pages taking their names from the nodes' names. Each *InfoElement* in a node is transformed into a *ContentNote* in the corresponding page. The name of the *InfoElement* is given to the *ContentNote*. The type of the *InfoElement* is used to build the wiki text that represents the *InfoElement* content. Compound *InfoElements*, that is, those made up from the aggregation of one or more *InfoElements*, are transformed into *ContentNotes* that act as containers of other *ContentNotes* generated from the component *InfoElements*. Other mappings are defined, but we omit them due to space limitations.

The page in Figure 7 contains the different *ContentNotes* generated from each *InfoElement* defined. The "FireInsideTunnel" *InfoElement* is showed on the left of the page (emergency coordinator view) and on the right (train driver and station chief views). On the top-center, we have the *ContentNote* generated to "SurfaceStreetMap" *InfoElement*, and below it, the one corresponding to the "DistanceIndicator" *InfoElement*. Finally, the "Tunnel" *InfoElement* appears at the bottom-center of the page; this component represents composite knowledge, and it was transformed into a compound *ContentNote* that contains the digital objects associated to the formal (tunnel video) and the contextual knowledge (warning image) elements. Both knowledge elements can be visualized in the same page using the spatial and visual features of ShyWiki.

CONCLUSIONS AND FURTHER WORK

Managing composite knowledge is a key issue in emergency responses. Giving responders the option to access to formal knowledge, even when it has been overwritten by contextual information, may improve the situational awareness of decision makers, which may result in more agile and confident instructions sent to responders. We have shown how a knowledge model including composite knowledge has allowed us to stereotype the classes in an emergency response plan model to classify its components in formal, contextual or composite. Then, strategies to derive implementation-independent navigational structures make the adoption of a specific platform easy.

Composite knowledge can be seen as a case of what other authors called Superimposed Information (Murthy, Maier, Delcambre and Bowers, 2004); in Superimposed Information architecture, a base layer can be combined with the superimposed one to create complex knowledge structures. To visualize superimposed information, however, some middleware is required. Another related approach was the Multivalent Browser (Phelps and Wilensky, 2000), which allowed to insert annotations and other extra information to documents. Again, specific software was needed to insert and access to such extra information.

ShyWiki, however, allows a simpler approach as its documents are visualized in regular web browsers. Moreover, the spatial features of its elements make it easy to access to both the base and contextual elements of a composite knowledge piece. The different types of multimedia information can be integrated in the hypermedia emergency response plans using a simple, Wiki-like language.

Future work includes the implementation of a tool supporting the framework, so that emergency response plan designers can define conceptual plan models which can be labeled with the different stereotypes and used to generate the navigational structures in a way as automated as possible. Then, different generators can obtain final emergency response plan versions using automated transformations. We also plan to evaluate the approach in other domains where composite knowledge is present. Finally, though we have shown how the use of wiki technology eases the collaborative editing of knowledge, we need to explore in more depth how a system like ShyWiki can be used by responders (normally equipped with small, mobile devices).

ACKNOWLEDGMENTS

The work of J. H. Canós, M. C. Penadés and M. Llavador is partially funded by the Spanish *Ministerio de Educación y Ciencia* (MEC) under projects META (TIN2006-15175-C05-01) and DEEPEN (TIN2009-08084), the *Junta de Comunidades de Castilla-La Mancha* under project INGENIO (PAC08-0154-9262) and the *Generalitat Valenciana* under grant ACOMP07/216. M. Llavador is the holder of the MEC-FPU grant no. AP2005-3356. The work of C. Solís is funded by Science Foundation Ireland, grant 03/CE2/I303 1 to LERO. The work of M. R. S. Borges is partially supported by grants No. 304252/2008-5 and 480461/2009-0, respectively, from CNPq (Brazil). The cooperation between the Brazilian and the Spanish research groups was partially sponsored by the CAPES/MECD Cooperation Program, Project #169/ PHB2007-0064-PC

REFERENCES

1. Bush, V. (1945) As we may think. *Atlantic Monthly*, 176(1):101–108.
2. Canós, J.H., Alonso, G. and Jaén, J. (2004) A multimedia approach to the efficient implementation and use of emergency plans. *IEEE Multimedia*, 11(3): 106-110.
3. Ceri, S., Fraternali, P. and Bongio, A. (2000) Web modeling language (WebML): a modeling language for designing web sites. *Computer Networks*, 33 (1-6): 137-157.
4. Diniz, V. B., Borges, M. R. S., Gomes, J. O. and Canós, J. H. (2008) Decision Making Support in Emergency Response. In: Frédéric Adam; Patrick Humphreys. (Org.). *Encyclopedia of Decision Making and Decision Support Technologies*. 1 ed. London: Information Science Reference (an imprint of IGI Global), 2008, v. 1, p. 184-191.
5. Engelbart, D.C. (1963) A conceptual framework for the augmentation of man's intellect. *Vistas in Information Handling*, 1:1–29.
6. Gahegan, M. and Pike, W. (2006) A Situated Knowledge Representation of Geographical Information. *Transactions in GIS*, 10, pp. 727–749.
7. Kahn, R. and Wilensky, R. (1995) A Framework for Distributed Digital Object Services. <<<http://www.cnri.reston.va.us/k-v.html>>>
8. Leuf, B. and Cunningham, W. (2001) *The Wiki way: quick collaboration on the Web*. Addison-Wesley Longman, Boston, USA.
9. Marshall, C.C. and Shipman, F.M. (1995) Spatial hypertext: designing for change. *Communications of the ACM*, 38(8): 88-97.
10. Murthy, S., Maier, D., Delcambre, L. and Bowers, S. (2004) Putting Integrated Information into Context: Superimposing Conceptual Models with SPARCE. In *Proc. of the First Asia-Pacific Conference of Conceptual Modeling (Denedin, New Zealand)*, 71-80.
11. Nonaka, I. and Takeuchi, H. (1995) *The knowledge-creating company: How Japanese companies create the dynamics of innovation*. Oxford: Oxford University Press.
12. Phelps, T. and Wilensky, R. (2000) Multivalent documents. *Communications of the ACM*, 43(6):83–90.
13. Schwabe, D. and Rossi, G. (1995) The object-oriented hypermedia design model. *Communications of the ACM*, 38(8):45-46.
14. Solis, C., Canós, J.H., Penadés, M.C. and Llavador, M. (2006) A model-driven hypermedia development method. In *Proc. of WWW/Internet. IADIS*.
15. Solis, C. and Ali, N. (2008) ShyWiki-A spatial hypertext Wiki. In *Proc. of the International Symposium on Wikis. ACM*.